

Print Reading: Plumbing Design

Unit: Graphic Agility

Problem Area: Print Reading—Lines and Symbols

Lesson: Print Reading: Plumbing Design

- **Student Learning Objectives.** Instruction in this lesson should result in students achieving the following objectives:

- 1 Review information contained on plumbing prints.**
- 2 Interpret plumbing print symbols and abbreviations.**
- 3 Create plumbing riser diagrams.**

- **Resources.** The following resources may be useful in teaching this lesson:

“Diagrams and Prints,” *Sydney Water*. Accessed Oct. 7, 2012.
<http://www.sydneywater.com.au/Plumbing/DiagramsAndPrints/>.

“Drawing Plumbing Plans,” *Chestofbooks.com*. Accessed Oct. 7, 2012.
<http://chestofbooks.com/home-improvement/construction/plumbing/Plans-Specifications/Drawing-Plumbing-Plans.html>.

“Engineering Symbolology, Prints, and Drawings,” *Scribd*. Accessed Oct. 7, 2012. <http://www.scribd.com/doc/7711916/Engineering-Symbols>.

Kubba, Sam A. *Blueprint Reading. Construction Drawings for the Building Trades*. McGraw-Hill, 2009.

“Plumbing Prints,” *Integrated Publishing: Draftsman*. Accessed Oct. 7, 2012.
<http://www.tpub.com/blueprintreading/23.htm>.

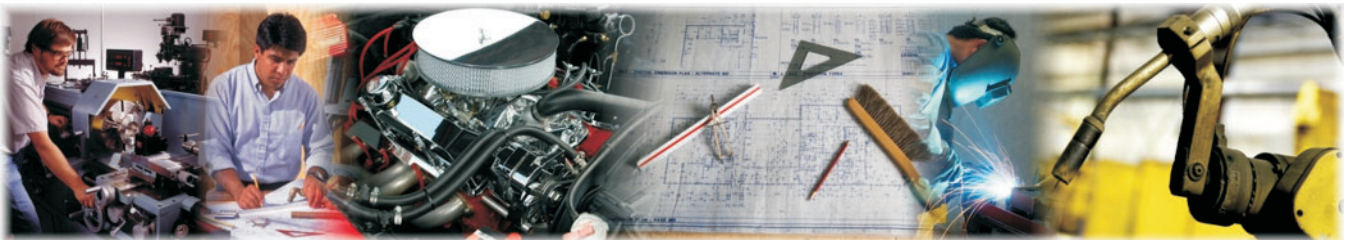

■ **Equipment, Tools, Supplies, and Facilities**

- ✓ Overhead or PowerPoint projector
- ✓ Visual(s) from accompanying master(s)
- ✓ Copies of sample test, lab sheet(s), and/or other items designed for duplication
- ✓ Materials listed on duplicated items
- ✓ Computers with printers and Internet access
- ✓ Classroom resource and reference materials

■ **Key Terms.** The following terms are presented in this lesson (shown in bold italics):

- ▶ drawing legend
- ▶ piping system
- ▶ plumber
- ▶ plumbing
- ▶ plumbing prints
- ▶ revision block
- ▶ revision cloud
- ▶ riser diagram
- ▶ supply diagram
- ▶ title block
- ▶ valves
- ▶ waste and vent stack diagram

■ **Interest Approach.** Use an interest approach that will prepare the students for the lesson. Teachers often develop approaches for their unique class and student situations. A possible approach is included here.

Plumbing prints have been in use for more than 1,000 years—as long as architectural and structural prints have been used. They are extremely important and are a required part of any design. Many of the symbols and diagrams used closely represent how the actual plumbing pieces appear and work. This really helps when learning how to read the designs.

CONTENT SUMMARY AND TEACHING STRATEGIES

Objective 1: Review information contained on plumbing prints.

Anticipated Problem: What information is shown on plumbing prints?

- I. **Plumbing prints** are drawings (blueprints) that detail the design, construction, and installation of a structure's supply lines, waste lines, fixtures, and other plumbing-related components. These prints provide the plumber and engineer with an overall view of the plumbing project and how the whole system would work, including fluid pressure.
 - A. Definitions
 1. A **plumber** is a person who installs, repairs, and maintains piping, fittings, and fixtures for water, sewage, and gas.
 2. **Plumbing** is the system of pipes and fixtures that moves water, sewage, and gas in a building.
 - B. To accurately read and understand the information on a plumbing print, it is necessary to know what each symbol and convention represents. It is also important to understand and know how to read the information contained on the main print and the information that is not contained in the main print drawing area. Aside from the main drawing area, there are four basic parts to prints (drawings).
 1. A **title block** is information that identifies the drawing is included in the title block; it is typically located on the right side or bottom of the print. The title block is broken down into several parts.
 - a. The first part of the title block is the drawing title and its number. They are located in the bottom right corner. The number is specific to that one drawing and usually includes a letter or code that locates that drawing within a construction set. For instance, the first plumbing print in a set would be "P1," and the next one would be "P2," and so on. The drawing number is used to file and organize the print in a series. The project site, the company that produced the drawing, and the drawing scale are typically noted here.
 - b. The second part of the title block contains the name of the designer or the design firm, the date of production, and signatures (in some cases). It may also list the various stages of the project and approvals for portions of the work.
 - c. The third part of the title block is the reference information or additional notes. It refers the reader to other prints in the set that are required to

understand a specific detail. Proprietary information about parts and materials is shown here.

2. A **drawing legend** is information that contains notes, symbols, and graphics used throughout the drawing(s). The symbols, abbreviations, and graphic conventions used are described here. There may be additional notes with drawing tags that explain and reference other required information.
3. A **revision block** is information that notes changes and the dates the revisions were made to the original drawing. It includes the first issue date and entries with revision numbers in chronological order. For example, (1) is the first revision and (2) is the second revision. Each revision must be indicated on the original drawing. This is typically done with a **revision cloud**, which is a line that consists of sequential arcs drawn around the portion of the drawing that has been revised. A revision cloud draws attention to that drawing element. In some cases, a symbol (e.g., a triangle) may be used. The symbol will have a number in it that references the change noted in the revision block.
4. The fourth part of the title block locates specific drawings on a print. This can be important, as some large-scale projects may have hundreds of drawings that reference each other. The system may use letters, numbers, or both. The top of the print is divided into equal portions; each portion is given a number or letter. The left side of the print is divided into equal portions, and each one is given a number or letter. This creates a series of small blocks (coordinates) that can be located by lining up a letter and number. A print grid system is similar to that of map coordinates.

Teaching Strategy: Use VM–A, VM–B, and VM–C. Invite a guest to class—an engineer, plumber, or designer—to speak to your students about the ways in which plumbing prints are now used and their importance to the building’s plumbing system.

Objective 2: Interpret plumbing print symbols and abbreviations.

Anticipated Problem: What symbols and abbreviations are used on plumbing prints?

II. Symbols and abbreviations

- A. Symbols (e.g., graphics, lines, and letters) used on plumbing prints are used to designate specific design details to build fluid systems. The symbols are standard across the trade and provide specific information about each element included in a piping system.
 1. Plumbing **valves** are devices that control the flow rate, pressure, and direction of fluids. The valve types can be manual, automatic, or remotely controlled.
 2. A **piping system** is a series of pipes, tubes, and hoses installed and organized to allow fluid (liquid or gas) to flow from one point to another. Piping system components include valves, flanges, bends, branches, nozzles, reducers, etc. The graphic lines used on piping prints have a separate designation for each

function. The symbols include a range of line types and may include letters or graphics within the lines.

3. Symbols designate fitting types and lines as well as how to redirect flow. Fittings are soldered and/or screwed. All of this information is noted within the symbols.
- B. Abbreviations on plumbing symbols are used to identify instrument types. They can be used to note a type of controller, a component, or a signal. Also, they can note the parameter used in control valves. Common plumbing print abbreviations are:
 1. F = Flow
 2. T = Temperature
 3. P = Pressure
 4. I = Current
 5. L = Level
 6. V = Voltage
 7. Z = Position

Teaching Strategy: Use VM–D through VM–I. Bring in a set of plumbing prints, and have students interpret the graphic information and symbols.

Objective 3: Create plumbing riser diagrams.

Anticipated Problem: What are plumbing riser diagrams?

- III. A plumbing **riser diagram** is a drawing that shows all plumbing supply and waste lines properly located, sized, and vented. This information can be shown in one drawing. In many cases, however, it is broken into two diagrams: the supply diagram and the waste and vent stack diagram.
 - A. Diagram types
 1. A plumbing **supply diagram** is a drawing that shows all the supply lines (tubes or hoses that carry fluid from the source to the terminal use) needed for each fixture in a system.
 2. A plumbing **waste and vent stack diagram** is a drawing that shows the waste lines for all the plumbing fixtures in a specific line and how they are vented. The drawings can be shown in a standard elevation, or they can be drawn in 3D.
 - B. A plumbing riser diagram traces how the cold water line reaches every fixture in the system from the main water supply. Also, it shows how water is supplied to the hot water heater and how it reaches every fixture in the system through the hot water lines. The pipes are sized to ensure the correct water pressure. Any required valves along the lines are shown in their proper location. The hot and cold water lines are drawn with their correct line type (or style). Each fixture that receives hot and/or cold water is designated with an abstract graphic or an image of the fixture. The type of fixture is noted on the print.

- C. The plumbing waste and vent stack diagram illustrates each fixture in the plumbing system, its waste line out of the building, and how the waste line is vented to ensure adequate air pressure. The lines are sized to maintain the proper flow and pressure. All fixtures are drawn with a required p-trap. The p-trap ensures the air pressure is vented out through the roof. The diagram locates all clean outs (C.O.) required at the end of each line.

Teaching Strategy: Use VM–J and VM–K. Demonstrate how to create a riser diagram—a supply or a waste and vent. Then have the students create one on their own. Assign LS–A with VM–L.

- **Review/Summary.** Use the student learning objectives to summarize the lesson. Have students explain the content associated with each objective. Student responses can be used in determining which objectives need to be reviewed or taught from a different angle. Questions at the ends of chapters in the textbook may be used in the Review/Summary.
- **Application.** Use the included visual master(s) and lab sheet(s) to apply the information presented in the lesson.
- **Evaluation.** Evaluation should focus on student achievement of the objectives for the lesson. Various techniques can be used, such as student performance on the application activities. A sample written test is provided.

■ **Answers to Sample Test:**

Part One: Completion

1. title block
2. piping system
3. valves
4. revision cloud
5. drawing legend
6. plumbing abbreviations (or abbreviations)

Part Two: True/False

1. T
2. T
3. F
4. T
5. T
6. F

Part Three: Short Answer

1. The five basic parts of a plumbing print are:
 - a. Main drawing area
 - b. Title block
 - c. Drawing legend
 - d. Revision block
 - e. Grid or organization system
2. The three parts of a title block and a brief description are:
 - a. Identification—The drawing title and its number are located in the bottom right corner.
 - b. Designer or design firm information—The name of the designer or the design firm, the date of production, and signatures (in some cases).
 - c. Reference information or additional notes—It refers the reader to other prints in the set that are required to understand a specific detail.

Print Reading: Plumbing Design

► Part One: Completion

Instructions: Provide the word or words to complete the following statements.

1. The part of the plumbing print that contains information to identify the drawing is the _____.
2. A series of pipelines installed and organized to achieve a specific task is called a/an _____.
3. To control the flow rate, pressure, and direction of fluids, plumbers install _____.
4. A line that consists of sequential arcs drawn around a portion of the drawing that has changed is a/an _____.
5. The part of the plumbing print that contains the notes, symbols, and graphics used throughout the drawing is the _____.
6. Examples of _____ are ABV., CO., ID, and WC.

► Part Two: True/False

Instructions: Write *T* for true or *F* for false.

- ____ 1. The plumbing riser diagram traces the cold water line to every fixture in the system from the main water supply.
- ____ 2. Some abbreviations on plumbing symbols are used to identify instrument types.
- ____ 3. Plumbing valve types include manual, systematic, and remotely controlled.
- ____ 4. The grid or organizer system on prints is used to create a series of small blocks (coordinates) that can be located by lining up a letter and number.

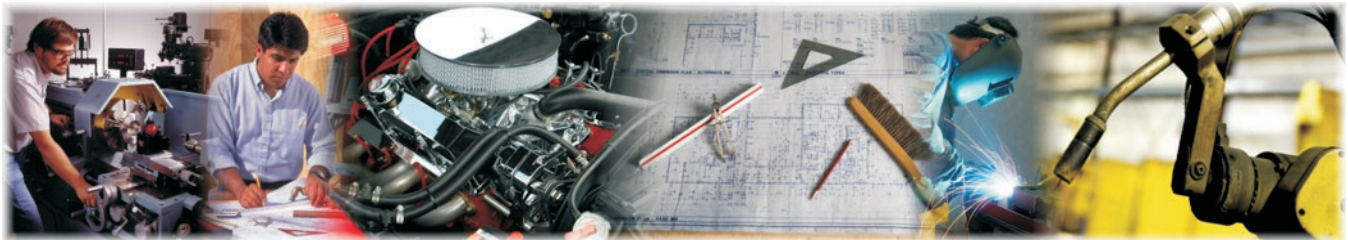

REVISION CLOUD

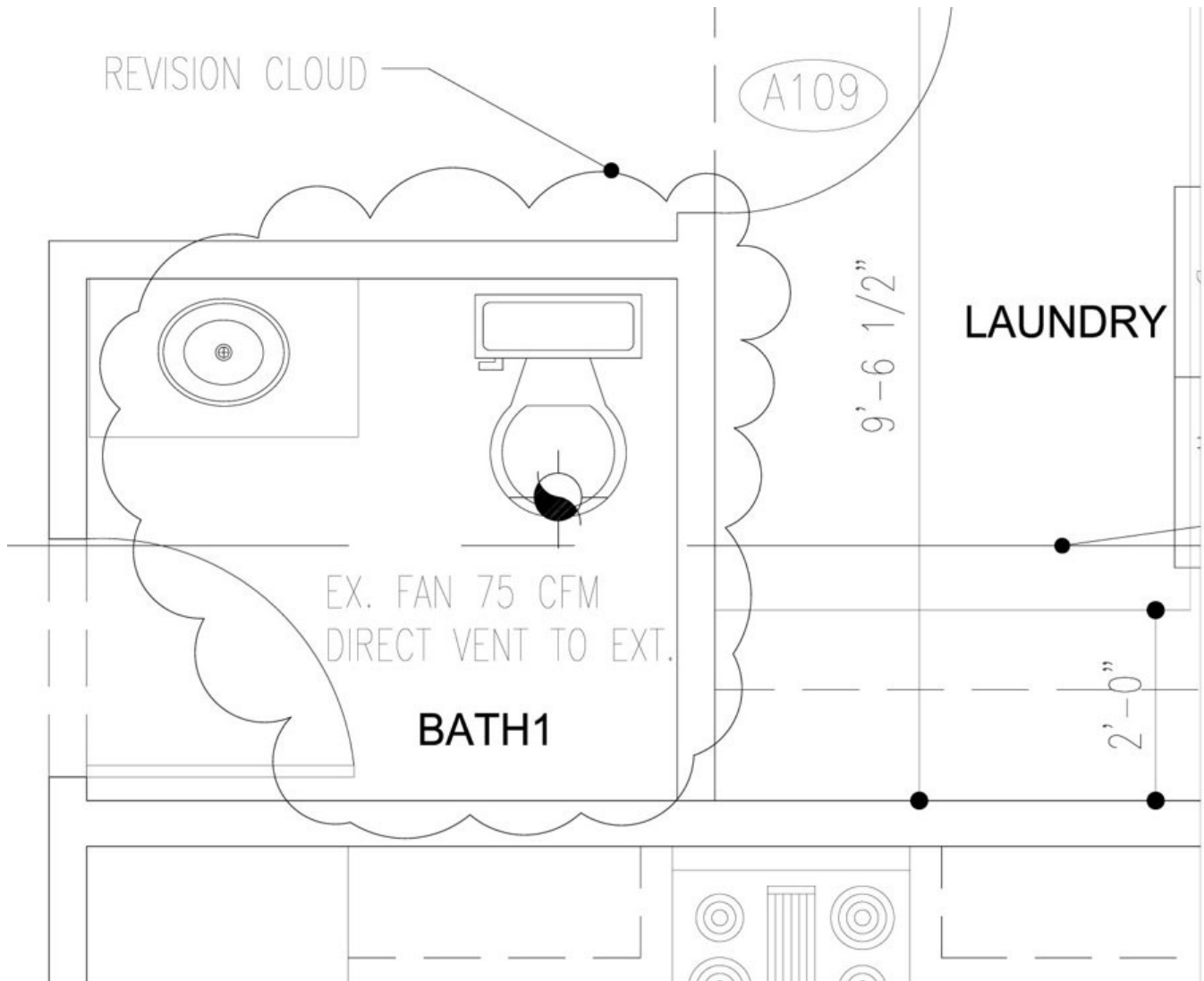

DRAWING GRID

	a	b	c	d	e	f	g	h	i	
1										
2										
3										
4										
5										
6										
7										
8										
9										
10										
										RESID. RENOVATION DATE: _____ DRAWN BY: _____ CHECKED BY: _____
										A1

PLUMBING PIPING SYMBOLS

TYPE	SYMBOL	TYPE	SYMBOL
CHILLED WATER SUPPLY	┌─── CWS ──┐	HOT WATER SUPPLY	┌─── HWS ──┐
CHILLED WATER RETURN	┌─── CWR ──┐	HOT WATER RETURN	┌─── HWR ──┐
COMPRESSED AIR	┌─── A ──┐	LOW PRESSURE STEAM	┌─── LPS ──┐
CONDENSATE DRAIN	┌─── CD ──┐	LOW PRESSURE CONDENSATE	┌─── LPC ──┐
FUEL OIL SUPPLY	┌─── FOS ──┐	REFRIGERANT SUCTION	┌─── RS ──┐
FUEL OIL RETURN	┌─── FOR ──┐	REFRIGERANT LIQUID	┌─── RL ──┐
FUEL GAS	┌─── G ──┐	REFRIGERANT HOT GAS	┌─── RHG ──┐
PUMPED CONDENSATE	┌─── PC ──┐		

PLUMBING VALVE SYMBOLS

TYPE	SYMBOL	TYPE	SYMBOL
ANGLE GATE VALVE		TEE (OUTLET DOWN)	
ANGLE GLOBE VALVE		BACKFLOW PREVENTER	
PLUG VALVE		UNION	
FLEXIBLE CONNECTOR		REDUCER	
FLOW SWITCH		CHECK VALVE	
PRESSURE GAUGE AND COCK		GATE VALVE	
PRESSURE/TEMPERATURE PLUG		GLOBE VALVE	
STRAINER, BLOW DOWN		BALL VALVE	
THERMOMETER		BUTTERFLY VALVE	
THERMOMETER WELL		DIAPHRAGM VALVE	

PLUMBING PIPING SYMBOLS AND CONNECTIONS

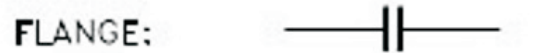
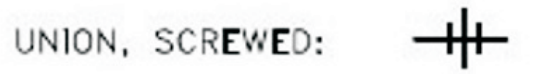
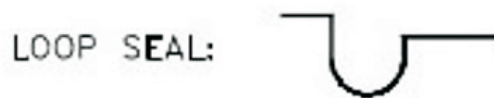
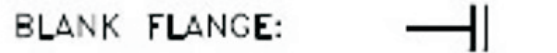
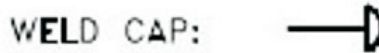
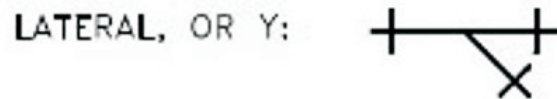
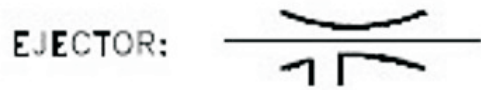
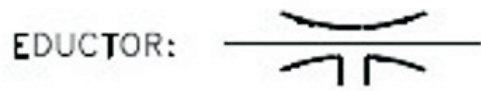

PLUMBING SYMBOLS: PIPING

PIPE TURNING
DOWN OR AWAY



PIPE TURNING
UP OR TOWARD



BREAK—PIPE CONTINUES



VENT



DRAIN OR WASTE
BELOW GROUND



DRAIN OR WASTE
ABOVE GROUND



COLD WATER



HOT WATER



HOT WATER
HEAT SUPPLY















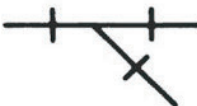

HOT WATER
HEAT RETURN

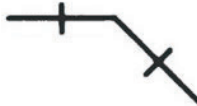

GAS

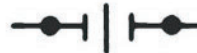

PLUMBING SYMBOLS: FITTINGS

FITTINGS	SCREWED	SOLDERED
TEE		
WYE		
ELBOW 90'		
ELBOW 45'		
CAP		
UNION		
CLEANOUT		
STOP VALVE		

COMMON PLUMBING ABBREVIATIONS

ABV.	above	LAV.	lavatory
AD	area drain	MTD.	mounted
AFF	above finished floor	NTS	not to scale
ALT.	alternate	OC	on center
CAP.	capacity	OD	outside diameter
CLG.	ceiling	OH	overhead
CO.	clean out	PRESS.	pressure
CONC.	concrete	PSI	pounds per square inch
CONT.	continuous	REV.	revision
DIA.	diameter	S	sink
DIM.	dimension	SCHED.	schedule
DWH	domestic water heater	SF	square foot
EXIST.	existing	SH	shower
FAI	fresh air inlet	S/STL	stainless steel
FD	floor drain	STP	standpipe
FIXT.	fixture	TS	tamperproof switch
FLEX.	flexible	VERT.	vertical
FPM	feet per minute	VOL	volume
GPH	gallons per hour	VTR	vent through roof
HB	hose bibb	WC	water closet
ID	inside diameter	WH	water heater
INV.	invert	WT.	weight

F = flow
T = temperature
P = pressure
I = current
L = level
V = voltage
Z = position
R = recorder
C = controller
M = modifier
E = element
P = pneumatic
FIC = flow indicating controller
FM = flow modifier
PM = pressure modifier
TE = temperature element
TR = temperature recorder
LIC = level indicating controller
TT = temperature transmitter
PT = pressure transmitter
FE = flow element
FI = flow indicator
TI = temperature indicator
FC = flow controller

PLUMBING RISER DIAGRAM

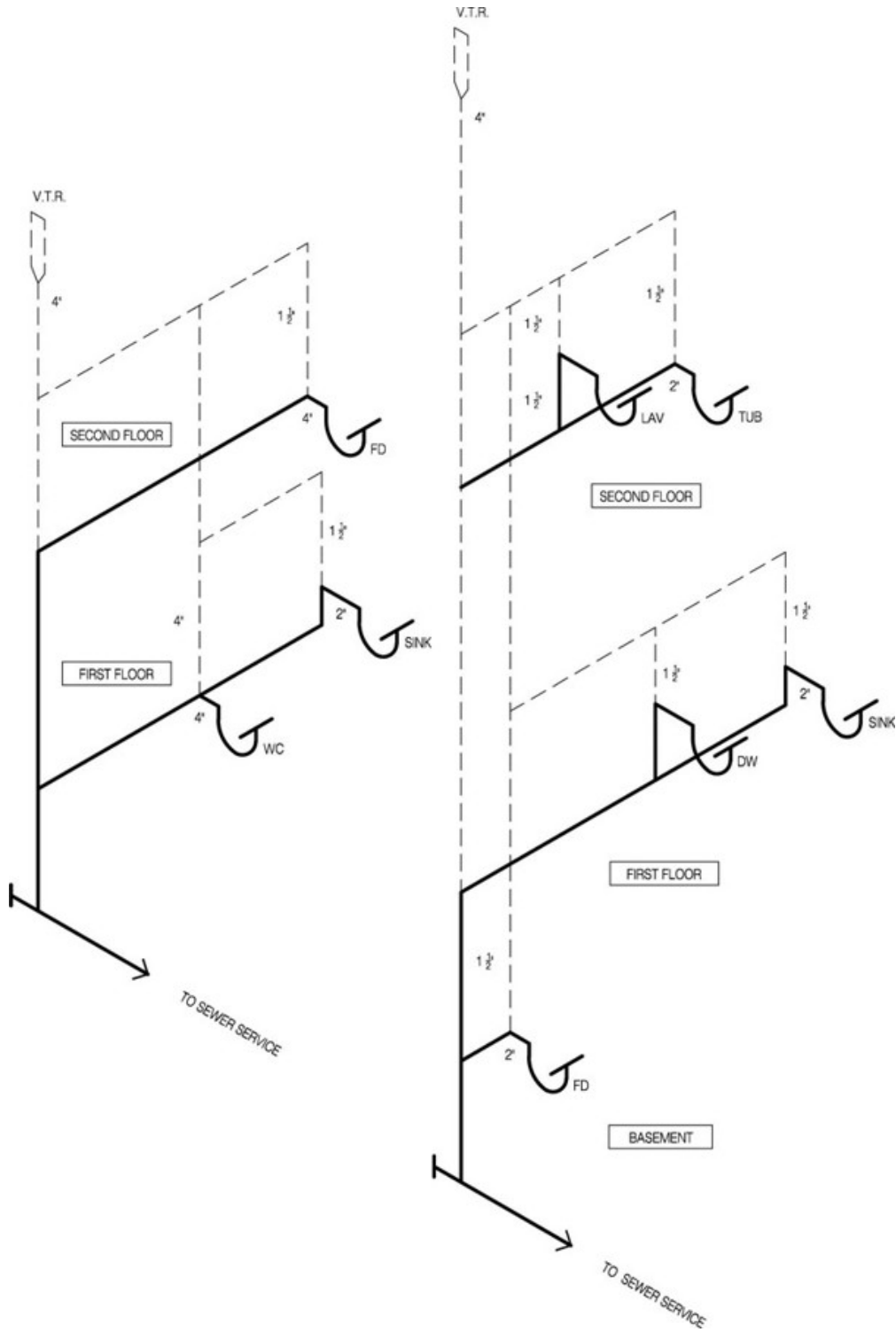

PLUMBING WASTE AND VENT STACK DIAGRAM

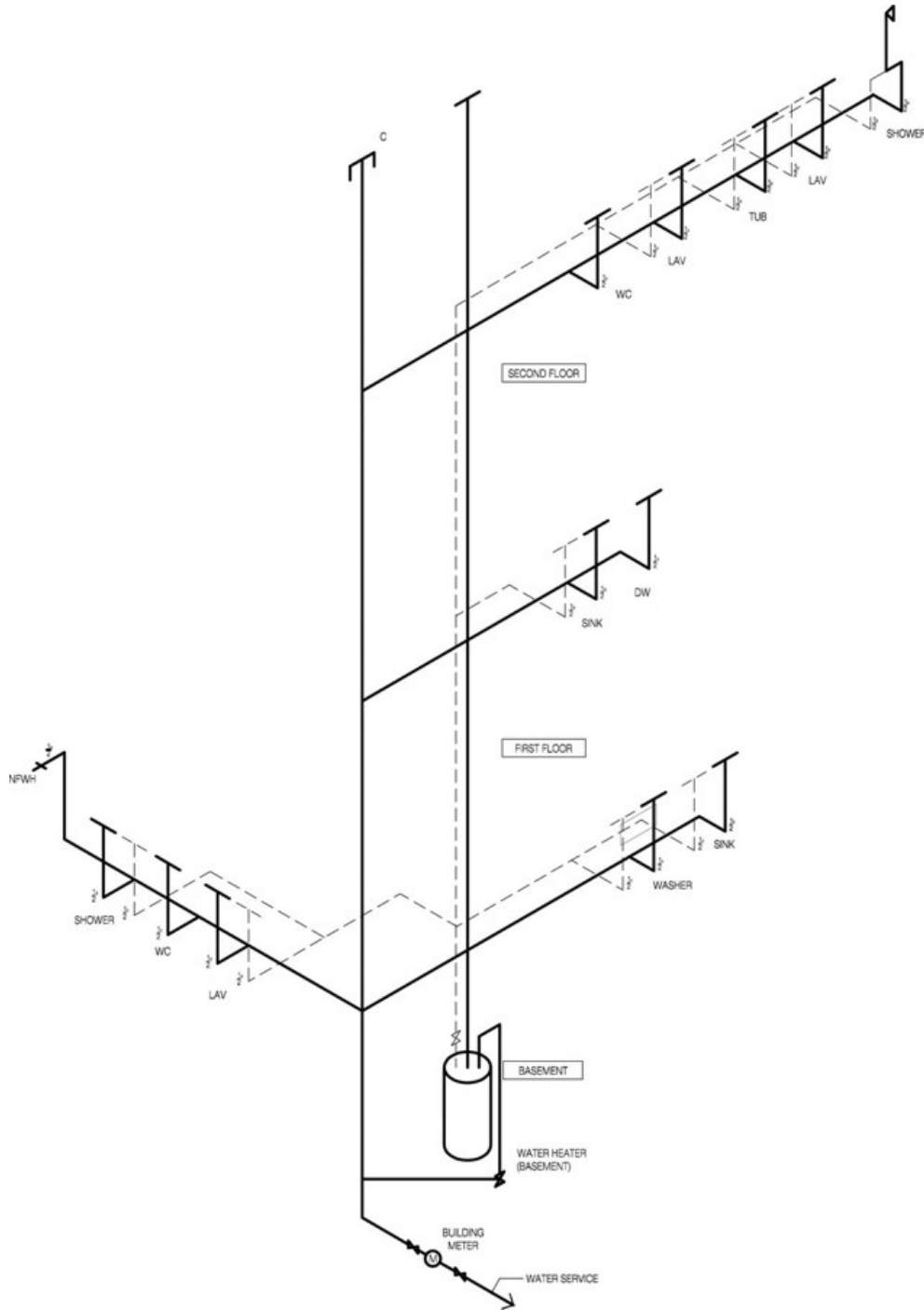

PLUMBING PLAN

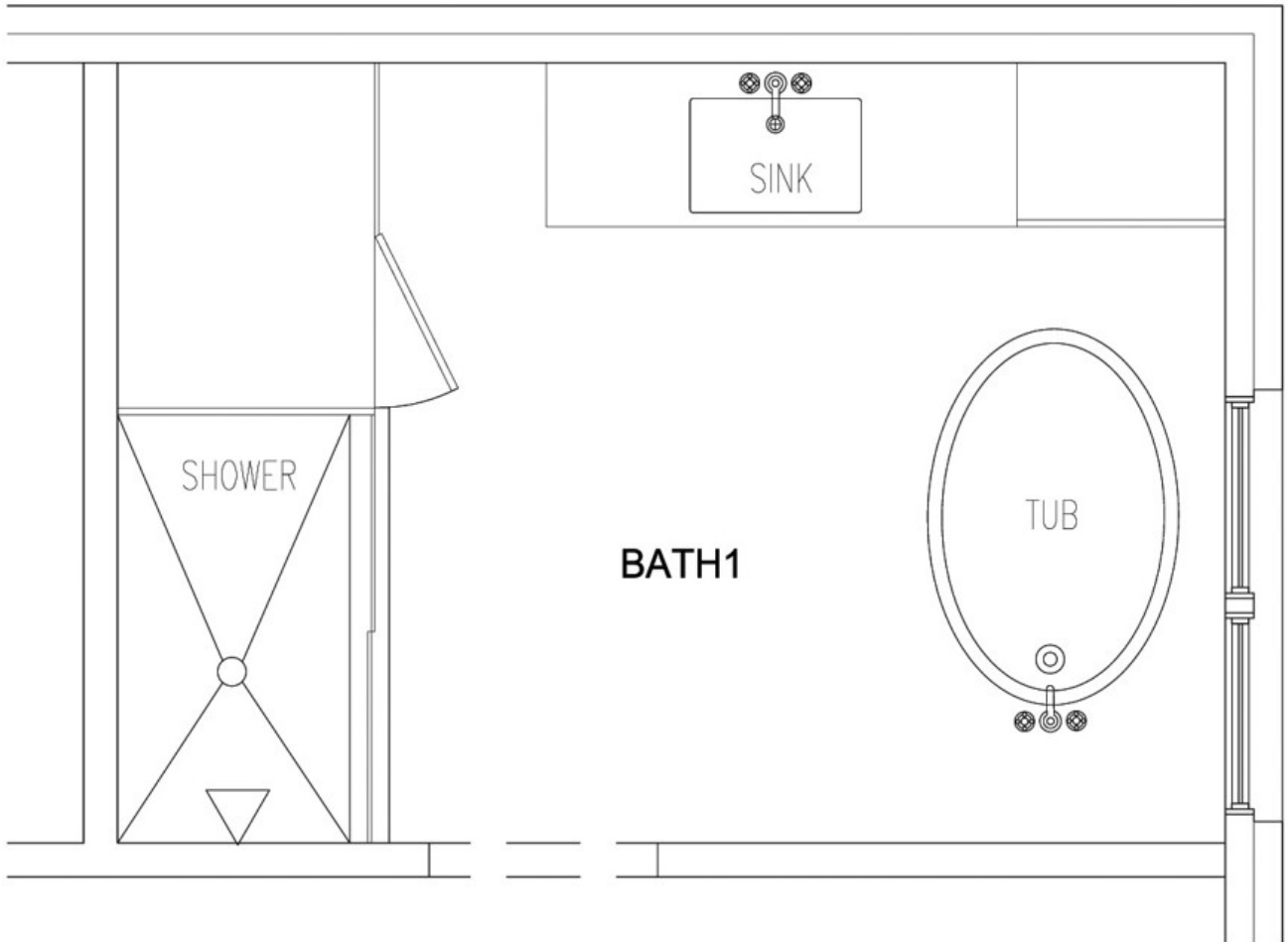

Draw Plumbing Prints

Purpose

The purpose of this activity is to insert the correct plumbing symbols and abbreviations in a riser diagram.

Objectives

1. Interpret and insert plumbing symbols and abbreviations.
2. Create a plumbing print.

Materials

- ◆ VM-L
- ◆ writing utensil
- ◆ paper
- ◆ class notes
- ◆ textbook

Procedure

1. Work independently.
2. Review your class notes about plumbing prints, symbols, abbreviations, and riser diagrams.
3. Draw a plumbing riser diagram using the VM-L basic plumbing plan. Follow the examples you have been shown and those in your reading. For your drawing, assume the plumbing plan is located in a basement and on a first floor.
 - a. Draw the main water supply line. Then split the line so one line goes to the hot water heater (which you must draw), and the other line is the cold water supply.

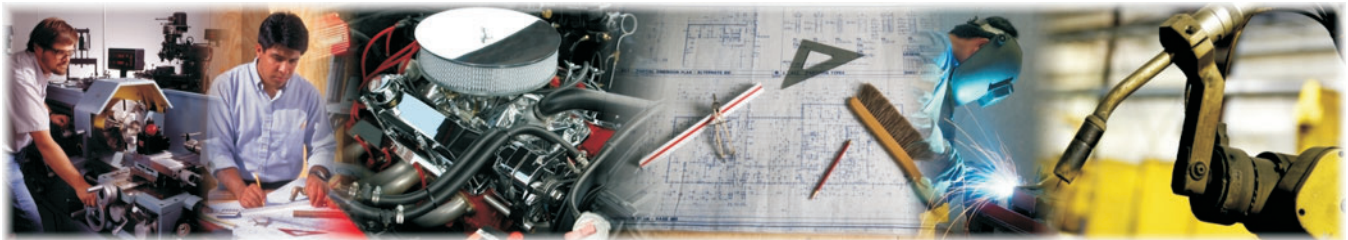

- b. Then draw a valve coming from the hot water heater and the appropriate plumbing line for the hot water to connect to the correct fixtures.
 - c. Next, draw the appropriate cold water lines that connect to the correct plumbing fixtures. (Remember, you can look at the sample you have from your reading.)
4. After you have drawn your lines, draw in the plumbing fixtures. You can use an image, graphic symbol, and/or abbreviation from your lesson examples. Then note the fixtures (e.g., sink, tub, and shower).
 5. After you have checked your work, ask your instructor to double-check it.
 6. Make any necessary changes to your drawing.
 7. Turn in your completed riser diagram to your instructor.